



**KIT**

Assembly Instructions

HayDay, LLC

1-800-732-1654

[www.StableGrazer.com](http://www.StableGrazer.com)

**Read completely through the assembly instructions before starting assembly.**



The Stable Grazer Kit comes in two boxes. Remove all the parts from the boxes and set them near your assembly area. To prevent damaging the door, assemble while still in the bottom half of the shipping container or use a large padded table. **Caution:** When removing the door be sure to hold it from the bottom to prevent it from opening in the frame. Do not remove the spacers and padding between the door and frame until final installation.

### Contents

The Feed Door and Frame are not shown in the parts below.

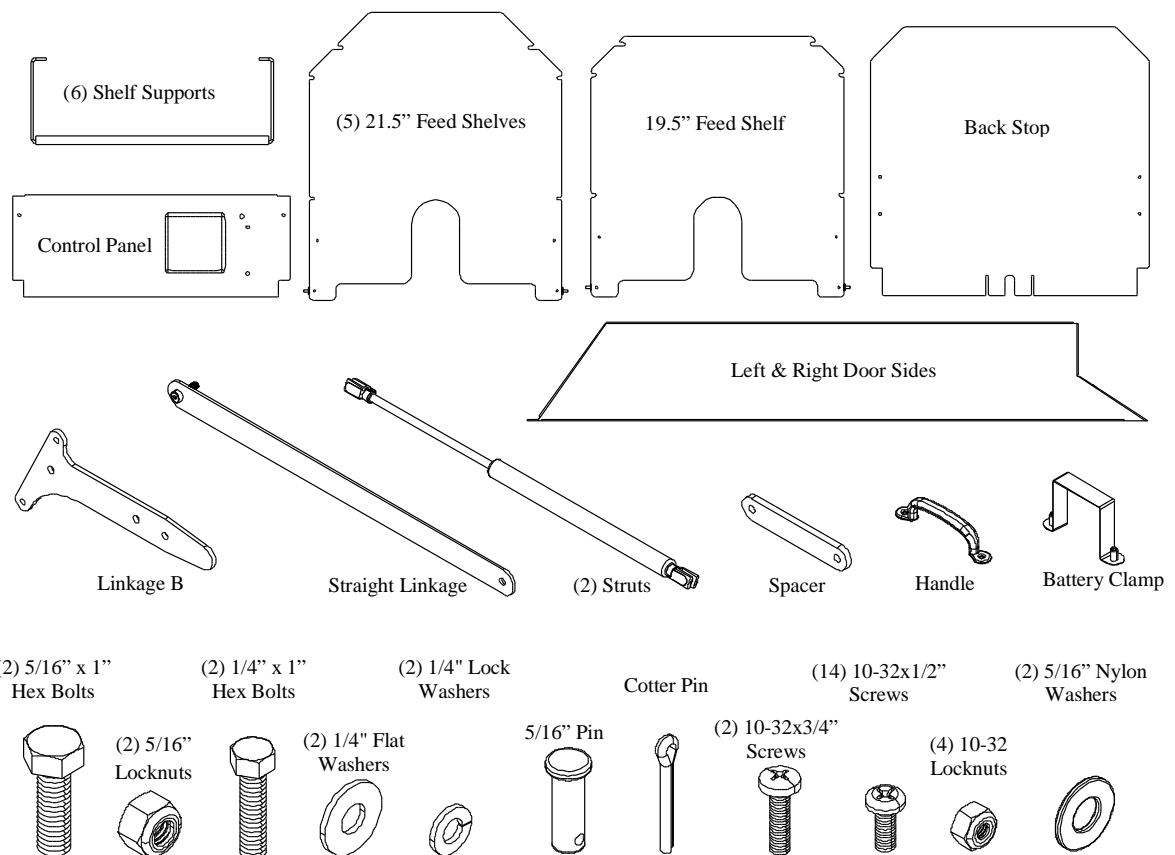

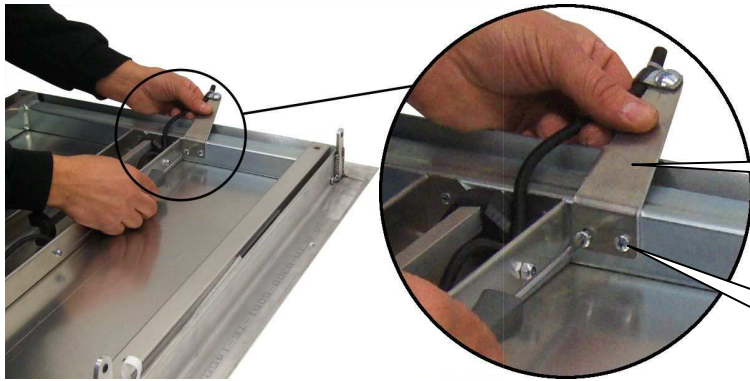

**1.** Attach the Shock Cord Bracket to the door using two 10-32 screws.

Shock Cord Bracket

(2) 10-32 Screws

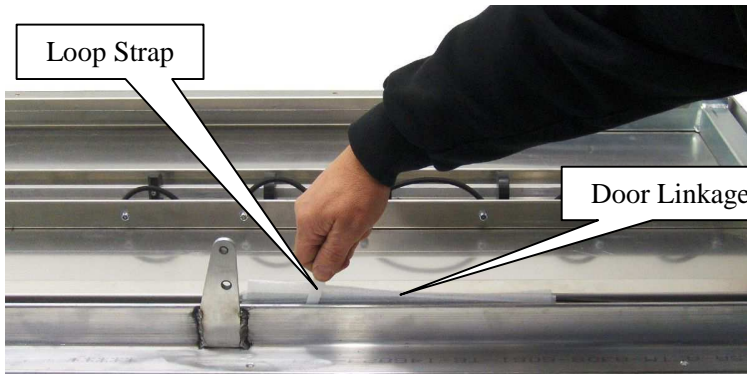

Loop Strap

Door Linkage

**2.** Lift the Door Linkage A from between the door and frame using the loop strap. Discard the foam and strap.

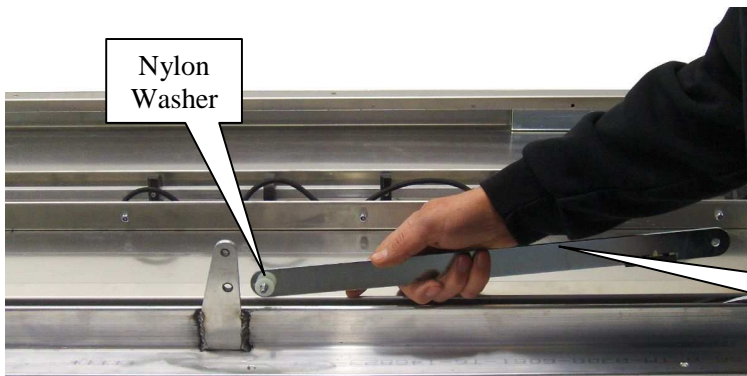

Nylon Washer

Straight Linkage

**3.** Install a nylon washer on the stud on the end of the Straight Linkage.



**4.** Slide the Straight Linkage stud through the 5/16" hole in the frame. Install another nylon washer and a 1/4" lock nut and tighten. Be sure the nylon washer fits over the shoulder on the Straight Linkage stud. The straight linkage should pivot freely when finished.

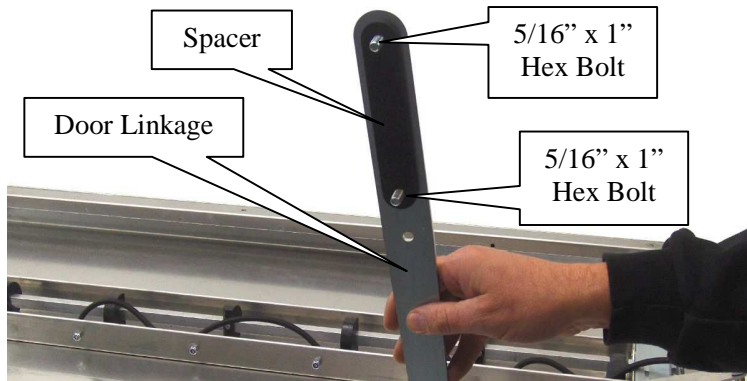

**5.** Install two 5/16" x 1" hex head bolts and the black *Spacer* on the Door Linkage A.

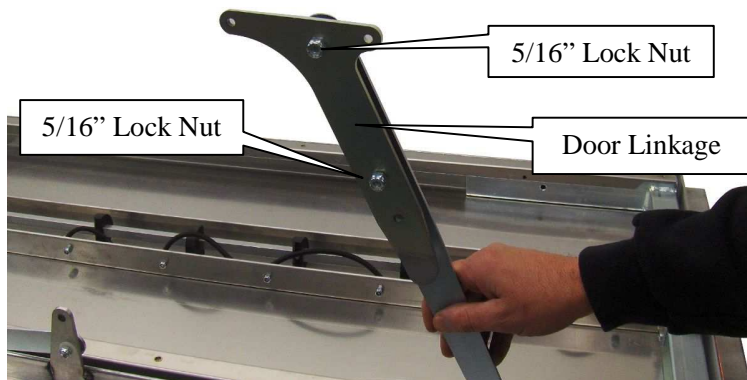

**6.** Install the Door Linkage B and two 5/6" lock nuts. Do not tighten at this time

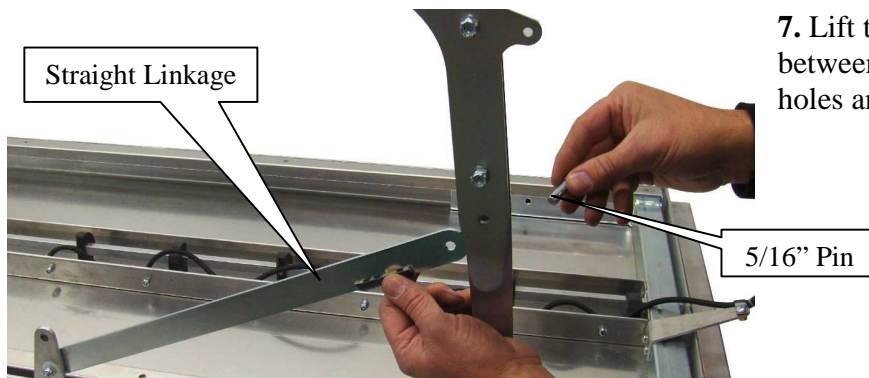

**7.** Lift the Straight Linkage into place between the Door Linkages. Align the holes and insert the 5/16" pin.

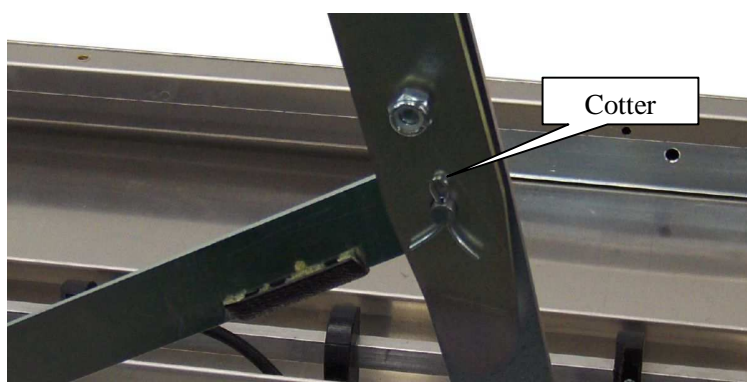

**8.** Insert the cotter pin through the hole in the 5/16 pin. Spread the cotter pin to secure it in place.

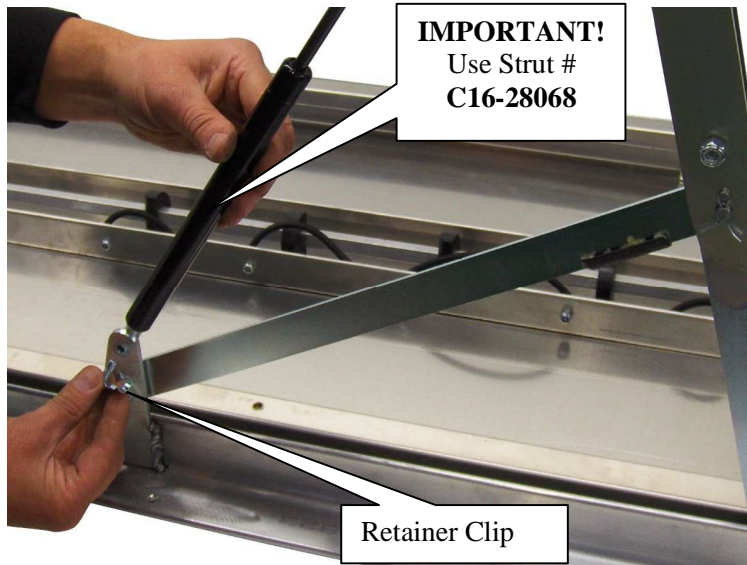

9. Remove the retaining clips from the ends of the Struts. Install the Strut with part # C16-28068 first. Be sure to install it exactly as shown (shaft end up). First attach the barrel end to the frame. Next attach the shaft end to the linkage. Be sure retaining clips snap firmly into place. **\*\*\*IMPORTANT: The Struts have different pressure amounts and must be installed in the correct positions. If installed incorrectly the door will not open and close properly.\*\*\***

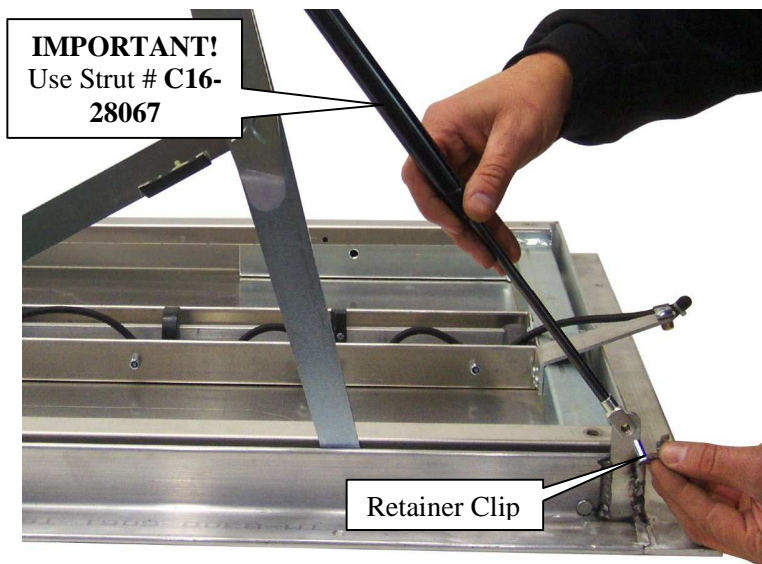

10. Now install the Strut with part # C16-28067. Be sure to install it exactly as shown (shaft end down). First attach the shaft end to the frame. Next attach the barrel end to the linkage. It may be necessary to compress the Strut slightly. Be sure retaining clips snap firmly into place. **\*\*\*IMPORTANT: The Struts have different pressure amounts and must be installed in the correct positions. If installed incorrectly the door will not open and close properly.\*\*\***

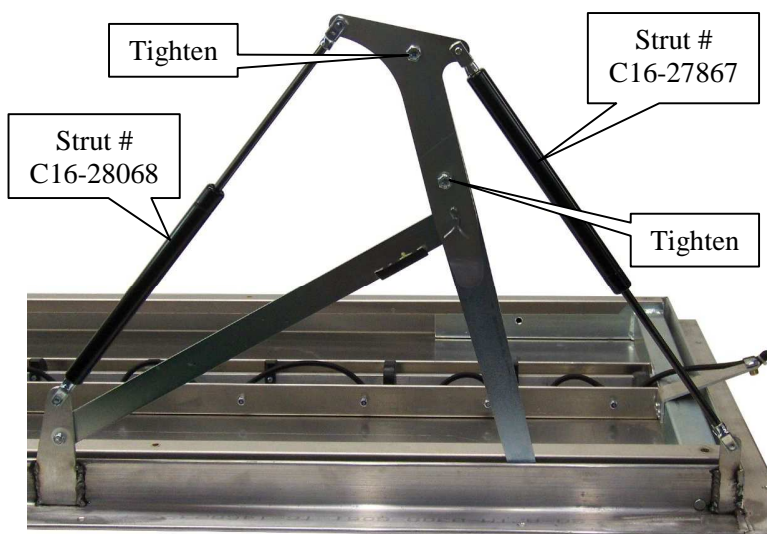

11. Your strut and linkage assembly should now look exactly like this. Tighten the two 5/16 hex bolts and nuts that were installed in steps 5 & 6.



**12.** Attach the left Door Side to the door using two 10-32 x 1/2" screws and a 1/4" x 1" hex bolt with lock washer and flat washer. Do not tighten at this time. Repeat for the right Door Side.

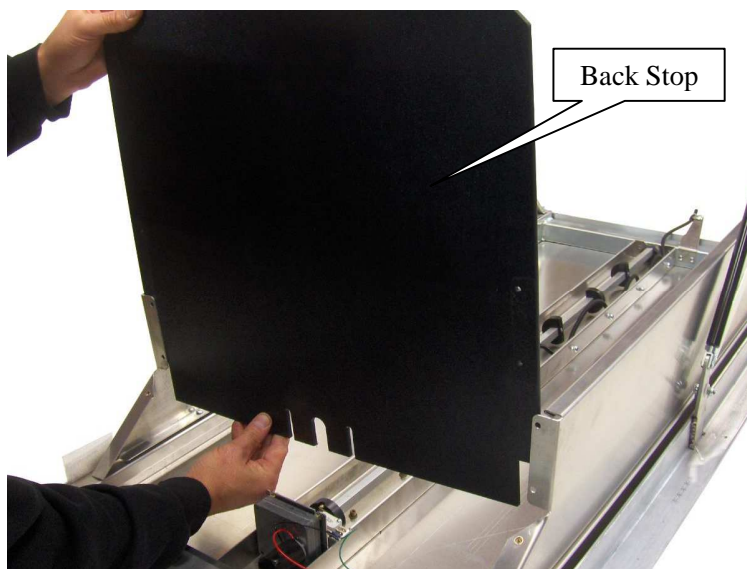

**13.** Slide the Back Stop into place with the textured side facing you.

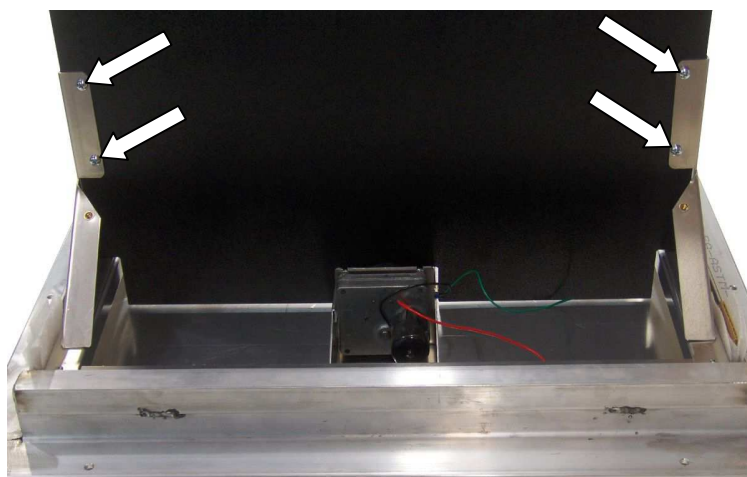

**14.** Install four 10-32 x 1/2" screws through the holes in the Door Sides and the Back Stop. Install a 10-32 lock nut on each screw and tighten.

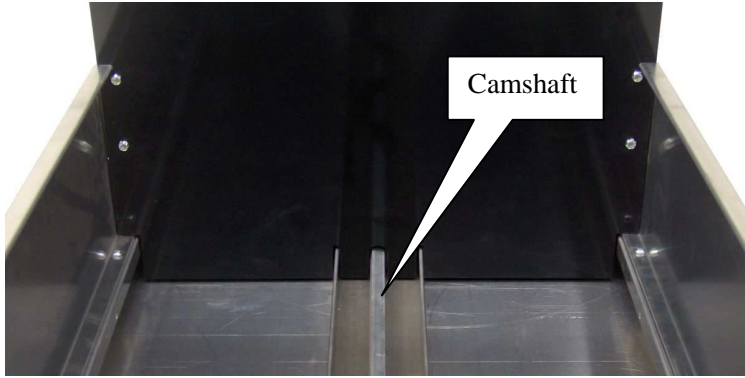

**15.** The Back Stop will shift slightly from side to side. Center the hole in the Back Stop over the camshaft and tighten all the screws and bolts installed in step 12.

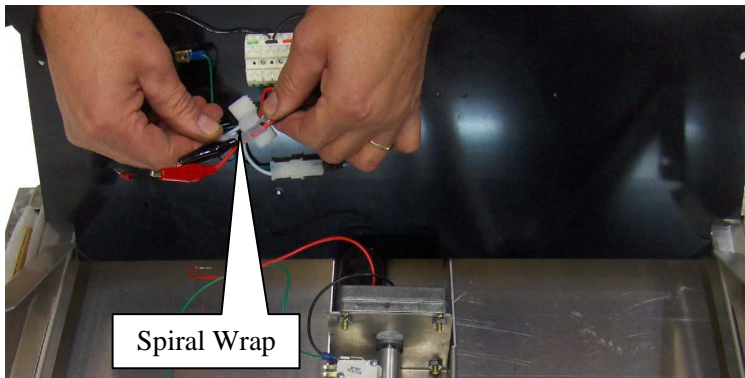

**16.** Remove the spiral wrap from the wires on the back of the Control Panel. **Note:** The Back Stop has been removed in steps 16 – 21 for clarity.

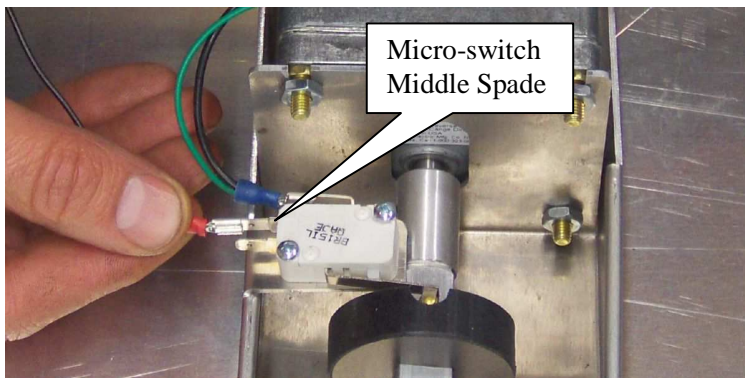

**17.** Attach the black wire from the Control Panel to the middle spade on the white micro-switch. The bottom spade on the micro-switch will be left blank.

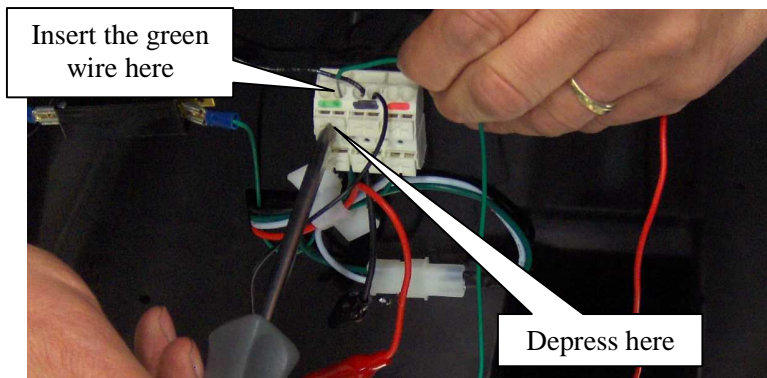

**18.** Attach the green wire from the top spade on the micro-switch to the terminal block on the Control Panel. The terminal block has spring loaded clips (using a screw driver may make depressing the clips easier). Depress the clip directly below the green marking on the terminal block and insert the green wire from the micro-switch. Release the clip and tug lightly on the green wire. If the wire does not pull out you are done, if it does, try

again.

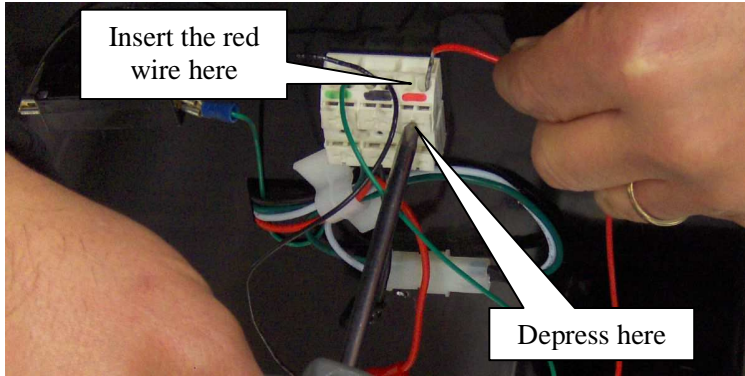

**19.** Using the same method as above attach the red wire from the motor to the terminal block on the Control Panel. Depress the clip below the red marking and insert the wire. Release the clip and tug lightly on the red wire. If the wire does not pull out you are done, if it does, try again.

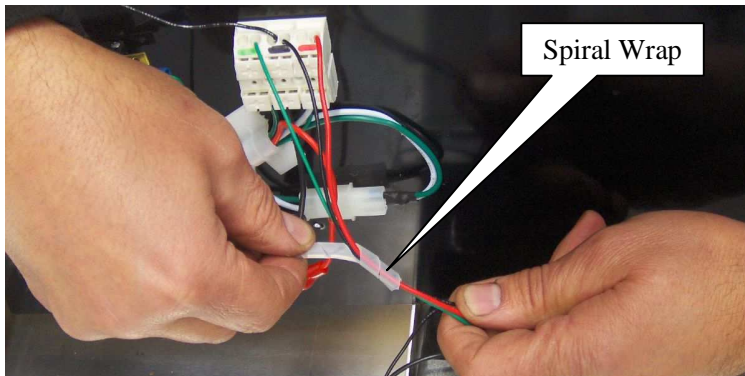

**20.** Group the red, green and black wires together. Re-install the spiral wrap around these three wires.

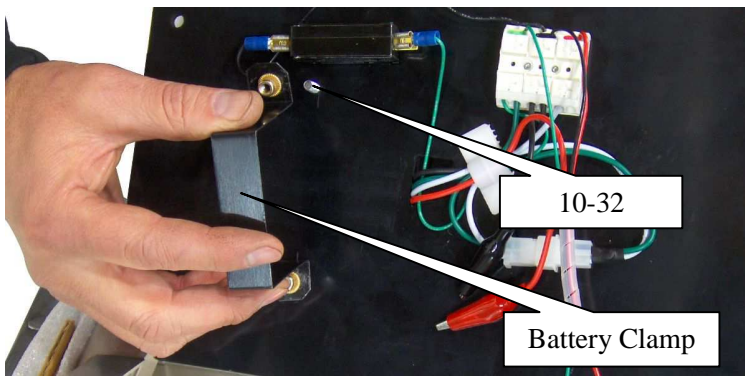

**21.** Attach the Battery Clamp to the back of the Control Panel by inserting two 10-32 x 3/4" screws through the holes just to the right of the Timer. Thread the screws partially into the Battery Clamp but do not tighten. Do not install the battery (not included) at this time.



**22.** Install the Control Panel by sliding it under the lip at the top of the door. Then tip it down until it rests against the angled part of the Door Sides. Install two 10-32 x 1/2" screws and tighten.



**23.** Leave the packaging shims in place for this step. While being careful not to let the door open in the frame set the feeder into your enclosure. Using appropriate fasteners (not included) attach it to your structure through the holes in the door frame as indicated by the white circles.

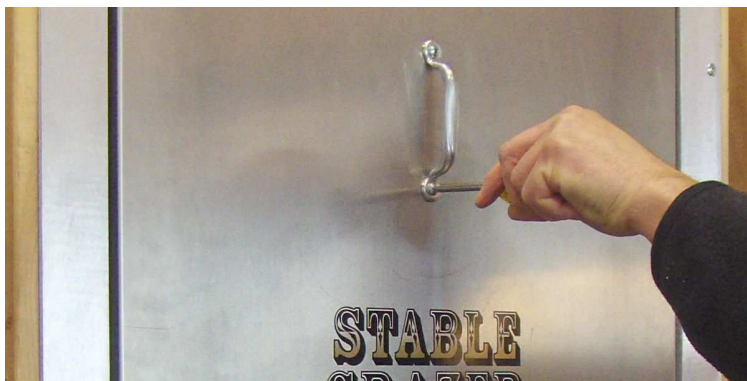

**24.** Attach the handle to the feeder door using two 10-32 x 1/2" screws.

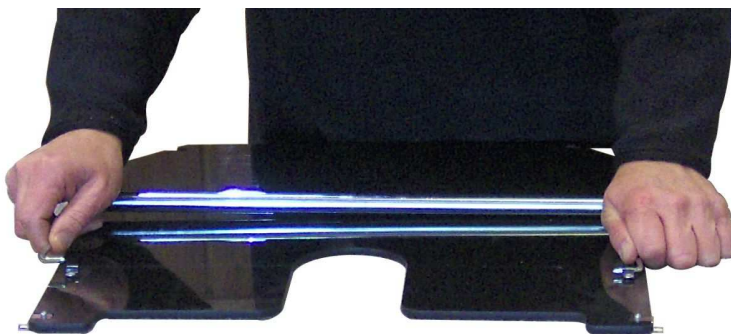

**25.** Remove the Shelf Supports from all six Feed Shelves by spreading the rod from the loop straps.

Pull the door open. As the door opens the packaging shims will fall out. You can discard them at this point. You may want someone to hold the door in the open position as you continue.



**26.** One Feed Shelf is shorter than the other five, start with this shelf. While standing on the left side of the door and starting from the end furthest from the Control Panel, install the Feed Shelves with the textured side up. Place the hinge pin in the first hole nearest you then flex the shelf enough to insert the opposite hinge pin in the corresponding hole on the opposite side. Continue until all the Feed Shelves are installed.

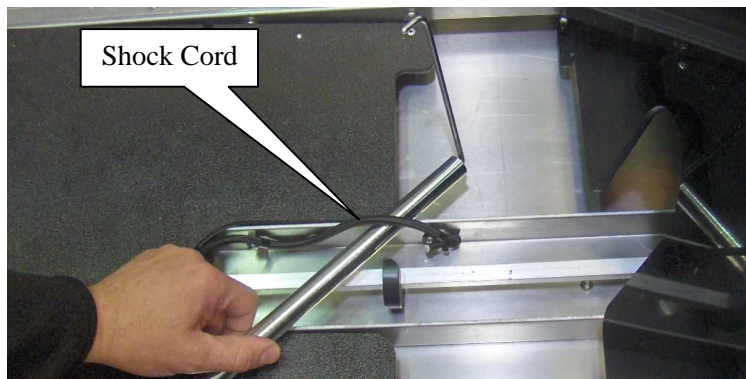

**27.** Flip the top shelf over so it rests against the Back Stop. Slide a Shelf Support through the top loop of the shock cord. Tip the shelf towards the rod and attach the Shelf Support to the bottom of the shelf.



**28.** Lift the shelf until the Shelf Support snaps over the cam. Repeat step 27 & 28 for each remaining shelf. **Do not skip any of the shock cord loops.**

Once the Shelf Supports are installed, start with the bottom shelf, lift the Shelf Support over the cam and lay each shelf down.



29. Remove the two 10-32 screws holding the Control Panel. Tip the Control Panel towards you to reveal the back side.

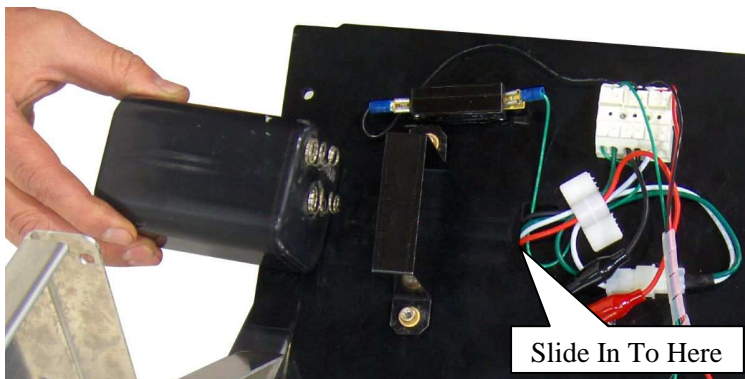

30. Slip a 6 Volt battery (not included) into the Battery Clamp. Slide it in until it just touches the wires coming through the Control Panel. Tighten the two 10-32 screws holding the Battery Clamp until the battery feels snug. **Note:** The Back Stop is removed for clarity.

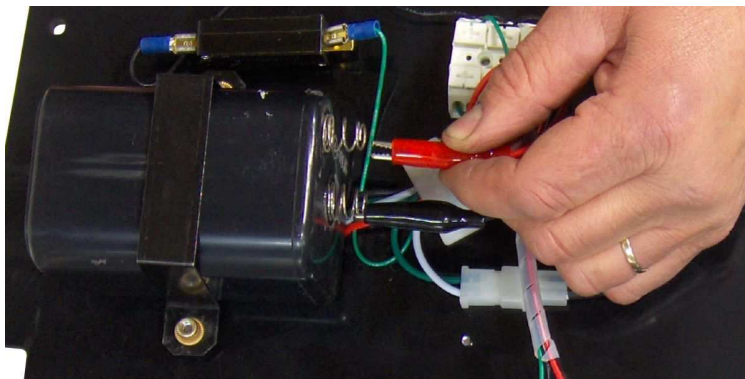

31. Attach the wires to the battery terminals. Take special care to attach the red wire to the positive (+) and the black wire to the negative (-) terminals. The timer display should now be active. Re-attach the Control Panel.



32. Test the connections by pressing the manual switch, the camshaft should begin to rotate. Continue to press the manual switch for two seconds then release. The camshaft should continue until it completes a 180° rotation. The camshaft should rotate in a counter clockwise direction when looking at it from the Control Panel end. If it rotates the wrong direction, check the positive and negative connections on the battery.

Your Stable Grazer Kit Feeder is now ready to program and use. The clear friction fit timer cover can be removed by lifting it away from the control panel. Please refer to the Owner's Manual or the decal to the left of the timer for programming instructions.